



## 4H243TI

Type	Rated RPM	Rated Power(kW/HP)	Max. Torque (N·m/rpm)
4H243TI-SE5A	2400	54.9 / 73.6	274.0 / 1500



### ◎ GENERAL ENGINE DATA

▶ Emission Level	EEC : StageV, EPA : Tier4 Final, Korea : Tier4
▶ Engine Type	4-cylinder, 4-Cycle, Diesel, Water cooled, Turbo, IC
▶ Bore x Stroke	Ø87×102.4 mm
▶ Displacement	2.435 liters
▶ Compression Ratio	17.4±0.2 : 1
▶ Combustor Type	Common Rail Direct Injection(CRDI)
▶ Rotation	Counter clockwise viewed from Flywheel
▶ Dimension (L x W x H)	934.3 x 566.9 x 726.7 mm
▶ Dry Weight	295kg (with Fan and housing type)
▶ High Idle Rpm	2550±50
▶ Low Idle Rpm	900±50
▶ Aspiration	Turbo Charged & Intercooler
▶ Governor Type	Electric Control (ECU)
▶ Injection timing	Auto Control
▶ Alternator Capacity	12V-75A
▶ Firing order	1-3-2-4
▶ Flywheel housing	SAE No.4
▶ Flywheel	Clutch No.7-1/2
▶ After Treatment	CCRT(DOC+DPF)

Specifications are subject to change without prior notice

### ■ CONVERSION TABLE

#### Power

$$\text{hp} = \text{Kw} \times 1.3405$$

$$\text{kW} = \text{hp} \times 0.7459$$

$$\text{kW} = [\text{torque(Nm)} \times \text{rpm}] / 9549$$

$$\text{hp} = [\text{torque(lb-ft)} \times \text{rpm}] / 5252$$

#### Torque

$$\text{Nm} = (9549 \times \text{Kw}) / \text{rpm}$$

$$\text{Nm} = 1.3558 \times \text{lb-ft}$$

$$\text{lb-ft} = (5252 \times \text{hp}) / \text{rpm}$$

$$\text{lb-ft} = 0.73756 \times \text{Nm}$$

$$\text{U.G gal} = \text{lit.} \times 0.264$$

$$\text{kW} = 0.2388 \text{ kcal/s}$$

$$\text{lb/PS.h} = \text{g/Kw.h} \times 0.00162$$

$$\text{cfm} = \text{m}^3/\text{min} \times 35.336$$

Revised on DEC 3, 2023





daedong

◆ ENGINE DIMENSION

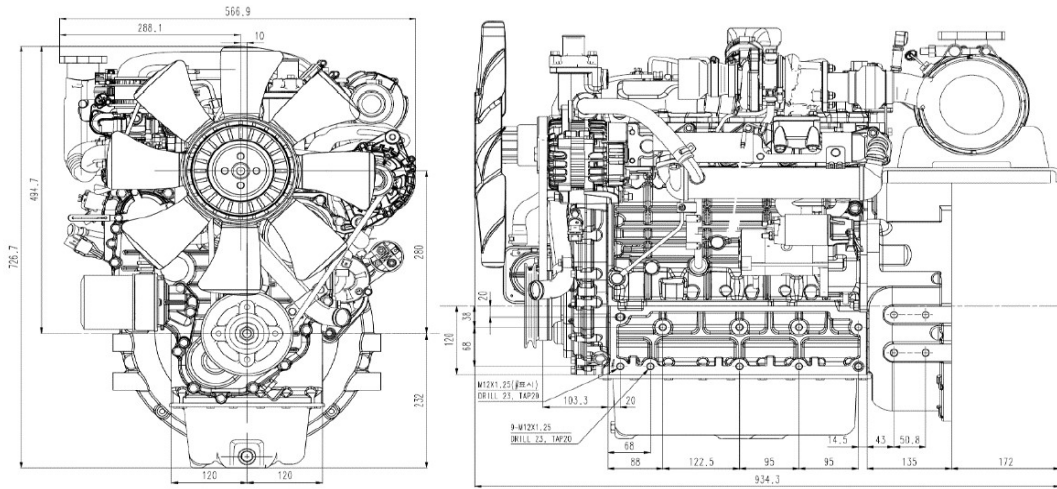

Designation	Length(L)	Width(W)	Height(H)	Dry weight
Value	934.3	566.9	726.7	295

◆ Performance Curve

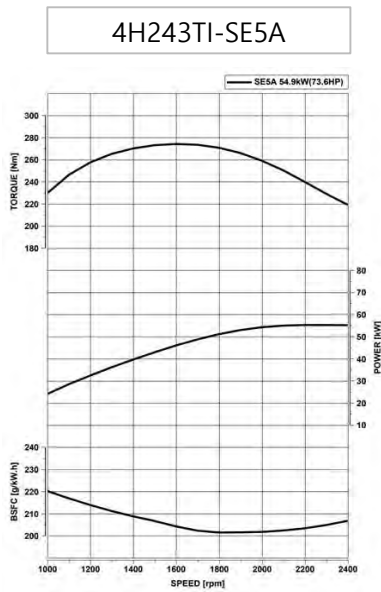

Revised on DEC 3, 2023



daedong